

ASH URN

- Surface Mounted
- Model 9724 – Satin Stainless Steel

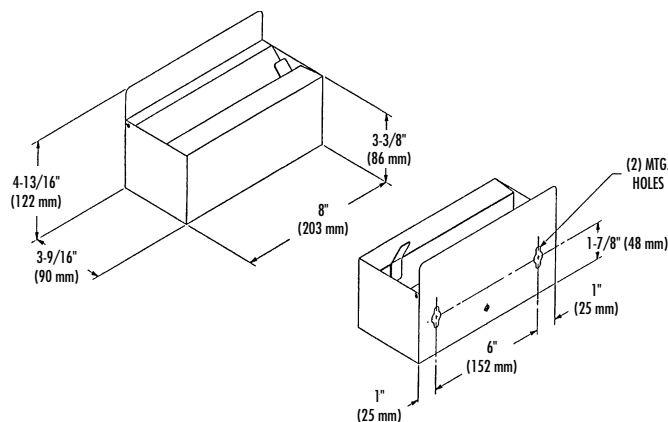

CONSTRUCTION:

- **BODY AND BACKPLATE** fabricated of type 304 (18-8), heavy gauge stainless steel with exposed surfaces in architectural satin finish.
- **FLIP TOP ASH TRAY** fabricated of type 304 (18-8), heavy gauge stainless steel with exposed surfaces in architectural satin finish with stainless steel push lever.
- **INNER ASH RECEPTACLE** fabricated of stainless steel.

OPERATION:

Flip Top Ash Tray is operated by pushing down on lever on right side of ash tray. Ashes fall into inner ash receptacle. To remove receptacle, lift hinged body and remove receptacle.

INSTALLATION:

Secure to wall with mounting screws (included) at holes provided.

GUIDE SPECIFICATION:

Surface mounted ash urn shall be fabricated of type 304 stainless steel with exposed surfaces in architectural satin stainless steel finish.

Flip top ash tray is permanently attached to receptacle body.

Overall dimensions: 8"W x 4-13/16"H x 3-9/16"D.

Surface Mounted Ash Urn shall be Bradley Model 9724.

Document No. 9080

This information is subject to change without formal notice.
© 2004 Bradley Corporation
12-22-2004

Bradley

P.O. Box 309, Menomonee Falls, WI 53052-0309
Phone 1-800-BRADLEY FAX 262-253-4161
Web Site: <http://www.bradleycorp.com>