

ASH URN

- Bowl Type
- Model 971 – Satin Stainless Steel

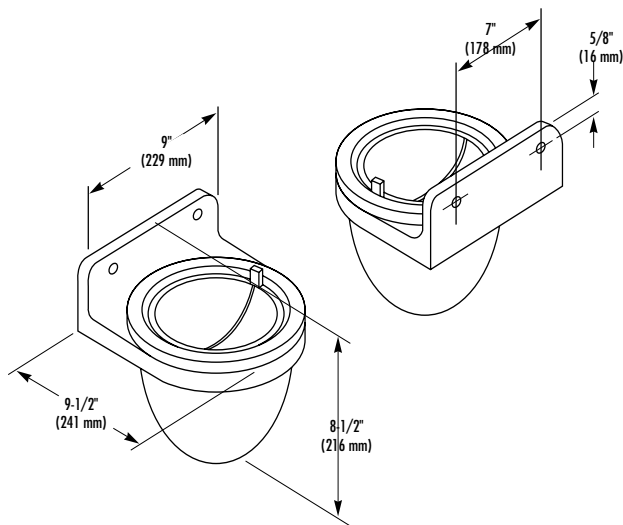

CONSTRUCTION:

- **Wall Urn** – Fabricated of type 304 (18-8), 22 gauge stainless steel with exposed surfaces in architectural satin finish, drawn construction.
- **FLIP TOP ASH TRAY** fabricated of type 304 (18-8), 22 gauge stainless steel with exposed surfaces in architectural satin finish. Drawn construction sits on top.
- **INNER ASH RECEPTACLE** of drawn, one piece seamless aluminum construction.

MOUNTING BRACKET:

- of heavy die cast aluminum.

OPERATION:

Split bowl opens to empty ashes into concealed waste receptacle. Top lifts to access receptacle which is removable for servicing.

INSTALLATION:

Secure to wall with mounting screws (included) at holes provided. (Adhesive back plate also available-see below.)

GUIDE SPECIFICATION:

Bowl type ash urn shall be fabricated of type 304, 22 gauge satin finish stainless steel with plunger operated split bowls and a removable aluminum ash receptacle.

Surface Mounted Ash Urn shall be Bradley Model 971.

Document No. 9075

This information is subject to change without formal notice.
© 2004 Bradley Corporation
12-22-2004

Bradley

P.O. Box 309, Menomonee Falls, WI 53052-0309
Phone 1-800-BRADLEY FAX 262-253-4161
Web Site: <http://www.bradleycorp.com>