

## SHOWER CURTAIN ROD

- Exposed Mounting
- Accommodates 60" Shower Stall
- Increases Space in Shower Stall

**Bradex®**

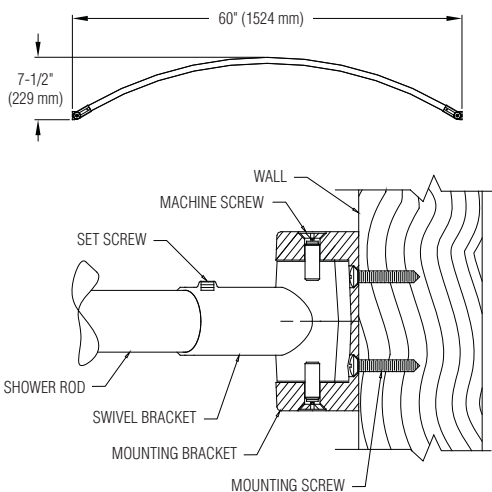

**Document No. 8971**

This information is subject to change without formal notice.  
© 2008 Bradley Corporation  
11-7-2008

### CONSTRUCTION:

- **SWIVEL BRACKETS** of chrome-plated zinc die cast. One-piece drawn construction with exposed surfaces in architectural satin finish.
- **TUBING** of stainless steel, seamless construction with exposed surfaces in architectural satin finish.

### INSTALLATION:

Verify all rough-in dimensions prior to installation. To properly engage rod in swivel brackets, loosen the set screw. Secure one flange to wall with mounting screws (included) at holes provided. Align mounting holes vertically. Slip opposite flange over rod and secure to opposite wall with rod in place. Mount in shower stall at desired height with mounting hardware provided. Some touch up may be required if old style flange was circular.

**NOTE:** When retrofitting or replacing a straight shower rod with Model 9530 curved shower rod, mount the new flange at the same location as the old flange. This will maximize the additional space a curved shower rod is designed to provide.

If properly mounted, the shower rod will withstand a maximum load of 50 lbs. without any sign of a permanent deflection.

### Optional Features

Feature	Suffix
<input type="checkbox"/> Bright Polished Finish	-78

**NOTE:** Swivel brackets exposed surfaces are in bright polished finish.

### GUIDE SPECIFICATION:

Shower curtain rod shall be fabricated of 18 gauge stainless steel in satin finish. Flanges shall be of 22 gauge stainless steel.

**Shower Curtain Rod shall be Bradley Model 9530.**

Orders composed of products indicated as **Bradex®** will be available to ship in one week after receipt of order at the factory. There is no pricing penalty for this service from Bradley.

**Bradley**

© 2008 Bradley Corporation  
P.O. Box 309, Menomonee Falls, WI 53052-0309  
Phone: 800.BRADLEY (800.272.3539) Fax: 262.253.4161  
bradleycorp.com