

SOAP DISH

- Surface-Mounted
- Stainless Steel – Extra Heavy Duty

Bradex®

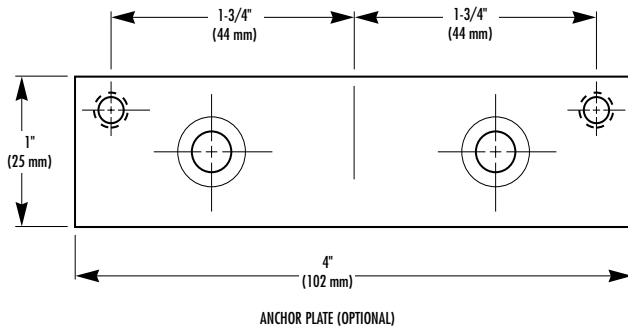
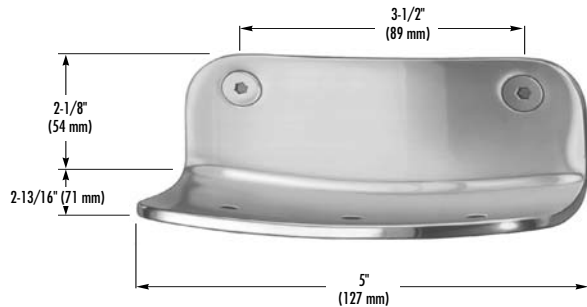

CONSTRUCTION:

- **SOAP DISH** fabricated of type 304 (18-8), 7 gauge stainless steel with exposed surfaces in architectural satin finish. Formed from single piece of stainless steel. Three drain holes in bottom.

OPERATION:

Three holes in bottom of tray permit water drainage.

INSTALLATION:

Secure to wall with mounting screws (stainless steel 1/4"-20 x 1-1/4" flat Allen head machine screws included) at holes provided.

OPTIONAL FEATURES

Feature	Suffix
<input type="checkbox"/> Cadmium-plated anchor plate	-59
<input type="checkbox"/> Zinc plated steel 1/4" x 1-1/4" flat head wood screws in lieu of machine screws	-61

GUIDE SPECIFICATION:

Extra heavy duty soap dish shall be fabricated of 7 gauge (0.1875") satin finish stainless steel and have three holes for drainage. Unit to be mounted with 1/4"-20 x 1-1/4" stainless steel flat Allen head mounting screws (included).

Overall dimensions: 5"W x 2-1/8"H x 2-3/4"D.

Soap Dish shall be Bradley Model 900.

Document No. 8885

This information is subject to change without formal notice.
© 2007 Bradley Corporation
4-3-2007

Orders composed of products indicated as **Bradex®** will be available to ship in one week after receipt of order at the factory. There is no pricing penalty for this service from Bradley.

Bradley 

P.O. Box 309, Menomonee Falls, WI 53052-0309
Phone 1-800-BRADLEY FAX 262-253-4161
Web Site: <http://www.bradleycorp.com>