

MIRROR

- Angle Frame – Welded Corners **Bradex**®
- Theft-Resistant Mounting

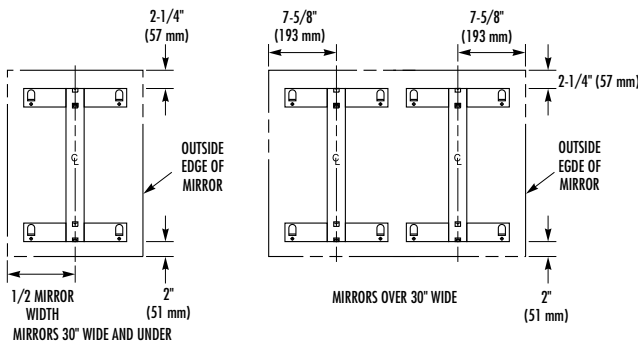
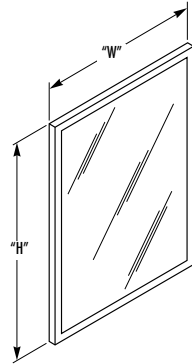

Bradex ® Models				
Width (Inches)	Height (Inches)	Overall Dimension (Inches)	Overall Dimension (Millimeters)	Standard Model Number
18"	30"	18 x 30	457 x 762	780-1830
18"	36"	18 x 36	457 x 914	780-1836*
24"	36"	24 x 36	610 x 914	780-2436*
24"	60"	24 x 60	610 x 1524	780-2460

Model 780 series angle framed mirrors can be fabricated to fit any architectural requirement. To specify sizes other than those indicated above, use the following formula: Model 780 + width in inches x height in inches. Example 780 - 3054.

* Indicates available Tempered glass. **Bradex**®

CONSTRUCTION:

- **FRAME** fabricated of heavy-gauge, one-piece roll-formed stainless steel, 3/4" x 3/4" angle with corners heliarc welded, ground and polished smooth to a satin finish. Double-strength continuous integral stiffener on all sides for added strength. Bevel on front of angle secures frame flush against mirror.
- **BACK** fabricated of galvanized steel, secured to frame with concealed screws, equipped with integral horizontal hanging brackets.
- **MIRROR** of first quality 1/4" float glass, triple silver plated with electro-copper plated layer and thermosetting infrared cured paint backing with Poly-Glaze protective finish. Meets federal specification DD-M-00411b against silver spoilage and guaranteed for 15 years. All edges protected by shock-absorbing, neoprene tubing.
- **WALL HANGER** fabricated of 18-gauge cold rolled steel, all welded construction to form rigid template.

INSTALLATION:

Secure concealed mounting bracket to wall with screws (not included) at holes provided. Mounting kits available through Bradley (ref. #899-026). Refer to technical data sheet #8880. NOTE: Provide in-wall backing at mounting screw locations. Position mirror over mounting bracket to engage hanger tabs. Slide mirror down and lock into position.

OPTIONAL FEATURES:

Feature	Suffix
<input type="checkbox"/> 1/4" tempered glass mirror in lieu of polished float glass mirror	-2
<input type="checkbox"/> Laminate glass	-3
<input type="checkbox"/> Highly polished No. 8 architectural finish, 20-gauge stainless steel in lieu of polished float glass mirror	-4
<input type="checkbox"/> Bright annealed 20-gauge stainless steel in lieu of polished float glass mirror	-5
<input type="checkbox"/> Plexiglass	-6

NOTE: An inherent characteristic of a manufacturing process is distortion which may vary from mirror to mirror.

GUIDE SPECIFICATION:

Mirror shall be framed with heavy-gauge, one-piece roll-formed 3/4" x 3/4" stainless steel angle with double-strength continuous integral stiffener. Welded corners shall be polished to a uniform satin finish. Mirror shall be of first quality 1/4" float glass guaranteed for 15 years against silver spoilage and protected by a shock absorbing, neoprene tubing with Poly-Glaze protective finish. Back of unit shall be galvanized steel secure to frame with concealed screws, equipped with integral horizontal hanging brackets and separate wall hanger for concealed mounting.

Framed Mirror shall be Bradley Model 780-_____ " W x _____ " H (specify width and height).

Orders composed of products indicated as **Bradex**® will be available to ship in one week after receipt of order at the factory. There is no pricing penalty for this service from Bradley.

Document No. 8775

This information is subject to change without formal notice.
© 2007 Bradley Corporation
7-27-07



P.O. Box 309, Menomonee Falls, WI 53052-0309
Phone 1-800-BRADLEY FAX 262-253-4161
Web Site: <http://www.bradleycorp.com>