

## STAINLESS STEEL MIRROR

- Unbreakable
- Stainless Steel
- Bright Annealed

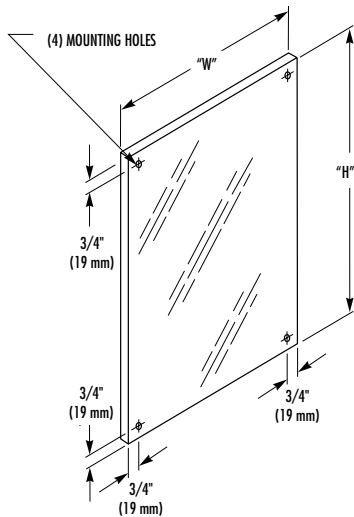

### CONSTRUCTION:

- **MIRROR** fabricated of type 430, 20 gauge bright annealed stainless steel. Material is stretcher leveled for uniformity. Surface is bright and smooth with mirror-like finish. 1/4" return conceals backing.
- **BACKING** of tempered Masonite bonded to mirror with adhesive.  
**NOTE:** Stainless steel mirrors will differ in optic quality from glass mirrors.

### INSTALLATION:

Secure to wall with tamper-resistant mounting screws (included) at holes provided.  
**NOTE:** Provide in-wall backing at mounting screw locations.

### GUIDE SPECIFICATION:

Mirror shall be fabricated of type 430 annealed stainless steel with bright, smooth reflective finish. Unit shall have 1/4" return to conceal 1/4" tempered Masonite backing bonded to mirror with adhesive.

**Stainless Steel Mirror shall be Bradley Model 7481- \_\_\_\_\_ " W x \_\_\_\_\_ " H (specify width and height).**

**APPROVED SUBMITTALS ARE REQUIRED FOR ALL MIRRORS LARGER THAN 24" X 24".**

In larger sizes, these units are subject to distortion and/or "oil canning" for which Bradley Corporation cannot accept responsibility.

**Document No. 8750**

This information is subject to change without formal notice.  
© 2007 Bradley Corporation  
3-14-2007

**Bradley**

P.O. Box 309, Menomonee Falls, WI 53052-0309  
Phone 1-800-BRADLEY FAX 262-253-4161  
Web Site: <http://www.bradleycorp.com>