



This unit meets "Barrier Free" requirements when mounted in accordance with local ordinances.

COMBINATION UNIT

- Partition-Mounted
- Serves Two Compartments
- Dual Roll Tissue Dispenser
- Napkin Disposal



CONSTRUCTION:

- **FLANGE** fabricated of type 304 (18-8) 22 gauge stainless steel with exposed surfaces in architectural satin finish. Flange of one piece seamless construction 1" wide with 1/4" return.
- **CABINET** fabricated of type 304 (18-8) 22 gauge stainless steel with exposed surfaces in architectural satin finish. Welded construction with burr-free edges.
- **DOOR** fabricated of type 304 (18-8) 18 gauge stainless steel with full length piano hinge and tumbler lock keyed like other Bradley units.
- **PUSH FLAP DOOR** fabricated of type 304 (18-8) 22 gauge stainless steel with exposed surfaces in architectural satin finish. Self-closing, with heavy duty stainless steel piano hinge.
- **WASTE CONTAINER** fabricated of leakproof molded plastic. 1.0 gal. capacity.
- **SPINDLES** of polyethylene, non-removable by user.

CAPACITY:

Toilet Tissue Dispensers-Four standard core toilet tissue rolls through 5-1/4" in diameter.

OPERATION:

Hinged access door permits servicing of components from one side.

INSTALLATION:

Requires partition opening 15-3/8"W x 18-1/4"H. Top of partition opening 4'0" above finished floor. For Barrier-free applications, top of partition opening 2'8" above finished floor. (Location of hole and dimensions should be noted in partition specifications.) Flanges adjustable for partitions from 3/8" to 2-3/4" thick. Remove one flange and install cabinet in partition opening flush against partition. Position flanges on both sides of cabinet and secure with mounting screws (included) at holes provided.

GUIDE SPECIFICATION:

Partition-mounted combination unit shall include toilet tissue dispenser and napkin disposal, and be fabricated of type 304 (18-8) heavy gauge stainless steel with seamless exposed surfaces in satin finish. Door and back panel shall be 18 gauge. Door shall have piano hinge and tumbler lock.

Overall dimensions: 17-1/8"W x 20"H x 4-1/2"D.

Partition-Mounted Combination Unit shall be Bradley Model 594.

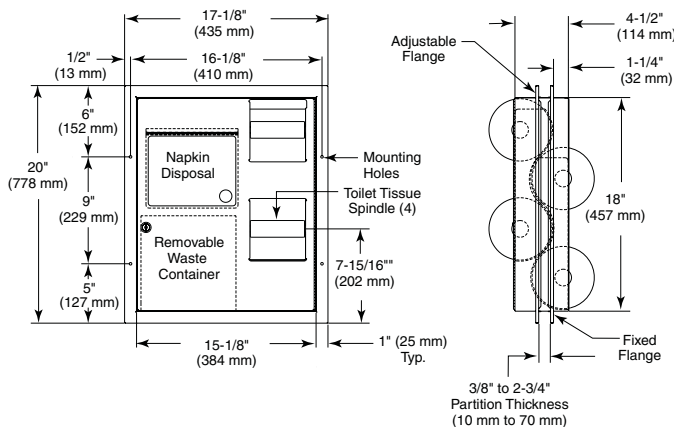

Document No. 8620

This information is subject to change without formal notice.
© 2007 Bradley Corporation
4-5-2007



P.O. Box 309, Menomonee Falls, WI 53052-0309
Phone 1-800-BRADLEY FAX 262-253-4161
Web Site: <http://www.bradleycorp.com>