



This unit meets "Barrier Free" requirements when mounted in accordance with local ordinances.

# TOILET TISSUE DISPENSER

- Recessed
  - Dual Roll
- Bradex®**



## CONSTRUCTION:

- **FLANGE** fabricated of type 304 (18-8), 22 gauge stainless steel with exposed surfaces in architectural satin finish. Flange of one piece seamless construction, 1" wide with 1/4" return.
- **CABINET** fabricated of type 304 (18-8), 22 gauge stainless steel with exposed surfaces in architectural satin finish. Welded construction with burr-free edges.
- **SERVICE DOOR** fabricated of type 304 (18-8), 22 gauge stainless steel with exposed surfaces in architectural satin finish and tumbler lock keyed like other Bradley units. Hinged at bottom.
- **SPINDLES** of molded polyethylene.

## CAPACITY:

Two standard core toilet tissue rolls through 5" in diameter.

## OPERATION:

Cabinet holds two rolls of 4-1/2" x 5" standard core toilet tissue, one above the other. When first roll is used-up, fresh roll automatically drops down for use. Unique retaining mechanism prevents use of spare roll until first roll is completely used. Spindles non-removable by user. Hinged door permits access to storage compartment for servicing of unit.

## INSTALLATION:

Requires rough wall opening 5-3/4"W x 10-1/2"H x 4"D. Top of wall opening 3'-0" above finished floor. Secure to framing with mounting screws (not included) at holes provided. Shim at screw points as required.

## GUIDE SPECIFICATION:

Recessed dual roll toilet tissue dispenser shall be heavy gauge satin finish stainless steel and hold two standard core toilet tissue rolls.

Overall dimensions: 7-5/8"W x 12-3/8"H x 5-5/16"D.

**Recessed Dual Roll Toilet Tissue Dispenser shall be Bradley Model 5412.**

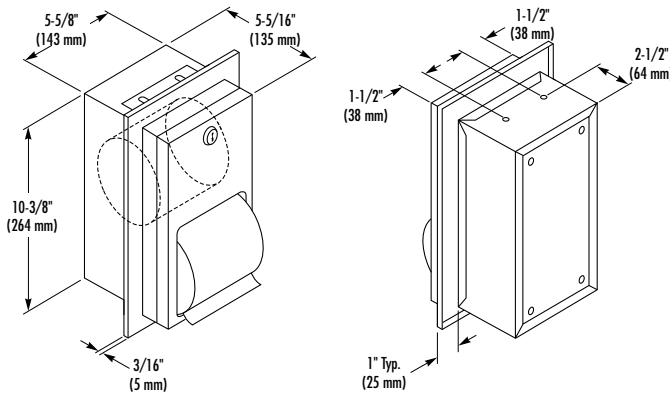

Orders composed of products indicated as **Bradex®** will be available to ship in one week after receipt of order at the factory. There is no pricing penalty for this service from Bradley.

**Document No. 8550**

This information is subject to change without formal notice.  
© 2007 Bradley Corporation  
8-30-2007



P.O. Box 309, Menomonee Falls, WI 53052-0309  
Phone 1-800-BRADLEY FAX 262-253-4161  
Web Site: <http://www.bradleycorp.com>