

Model 523

- Non-Controlled Delivery
- Dual Roll (For Single Roll see Model 508-32)

Product Materials

BRACKETS: die cast virgin zinc (Zamac) alloy; copper and nickel-plated with highly polished chrome finish.
MOUNTING BRACKET: heavy plated steel.
SPINDLES: chrome-plated plastic.

Capacity

Two standard core toilet tissue rolls through 4-1/2" in diameter.

Operation

Concealed spring permits spindle to telescope for servicing. Spindle turns freely for non-controlled delivery.

Installation

Verify all rough-in dimensions prior to installation. Secure concealed mounting brackets to wall with screws (included). Slip support arms over brackets and secure with concealed set screws.

Guide Specification

Surface-mounted dual roll toilet tissue dispenser shall be copper and nickel-plated die cast Zamac with highly polished chrome finish. Dispenser shall have separate wall mounting bracket and hold two standard core toilet tissue rolls.

Overall dimensions: 14"W x 1-7/8"H x 3-1/4"D.

 **ADA Compliant**

- Consult local and national accessibility codes for proper installation guidelines.
- Conformity and compliance to local and national codes is the responsibility of the installer.

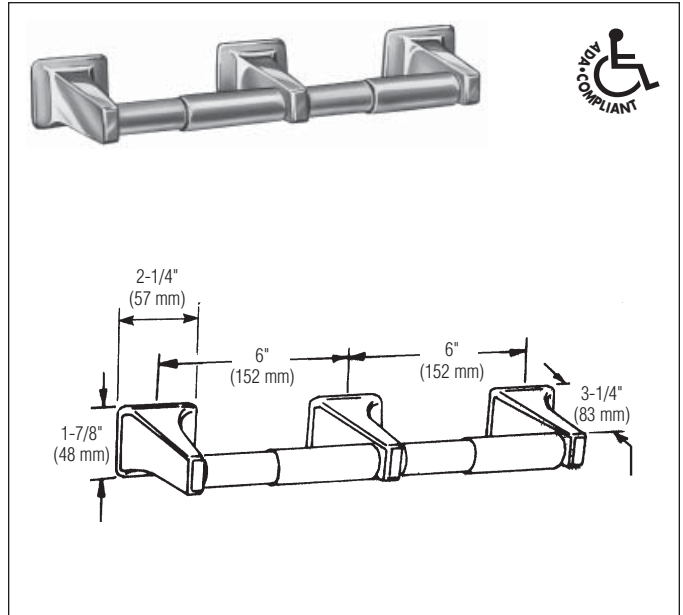

**Washroom Accessories
 Document No. 8505**