

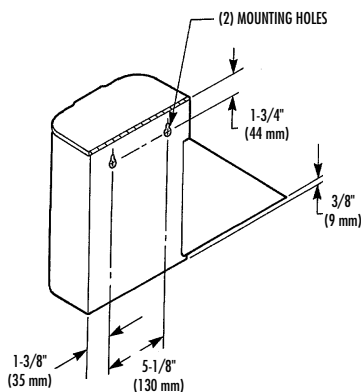

# NAPKIN DISPOSAL

- Surface Mounted
- With Shelf

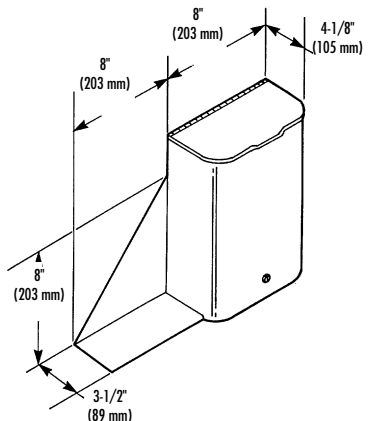
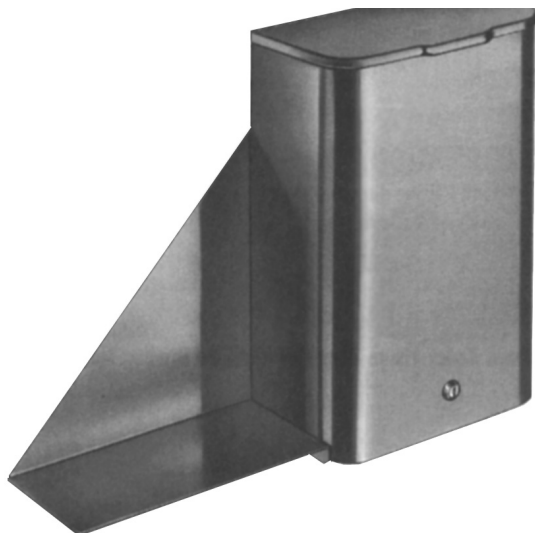

## CONSTRUCTION:

- **COVER** fabricated of type 304 (18-8), 22 gauge stainless steel with exposed surfaces in architectural satin finish. Heavy duty stainless steel piano hinge.
- **CONTAINER** fabricated of type 304 (18-8), 22 gauge stainless steel with exposed surfaces in architectural satin finish. All welded construction with rounded front corners. Bottom equipped with lock and heavy duty stainless steel piano hinge.
- **SHELF** fabricated of type 304 (18-8), 22 gauge stainless steel with exposed surfaces in architectural satin finish. Securely welded to container.

## OPERATION:

Bottom opens for removal of waxed paper liner. Additional liners available from Bradley.

## INSTALLATION:

Secure to wall or partition with mounting screws (included) at holes provided.

## GUIDE SPECIFICATION:

Surface mounted napkin disposal with shelf shall be fabricated of type 304 (18-8), 22 gauge stainless steel with exposed surfaces in satin finish. Top attached by piano hinge. Bottom hinged for easy servicing.

Overall dimensions: 16"W x 11-1/4"H x 4-1/8"D.

Surface Mounted Napkin Disposal shall be Bradley Model 4791-15.

Document No. 8420

This information is subject to change without formal notice.  
© 2004 Bradley Corporation  
12-21-2004

**Bradley**

P.O. Box 309, Menomonee Falls, WI 53052-0309  
Phone 1-800-BRADLEY FAX 262-253-4161  
Web Site: <http://www.bradleycorp.com>