

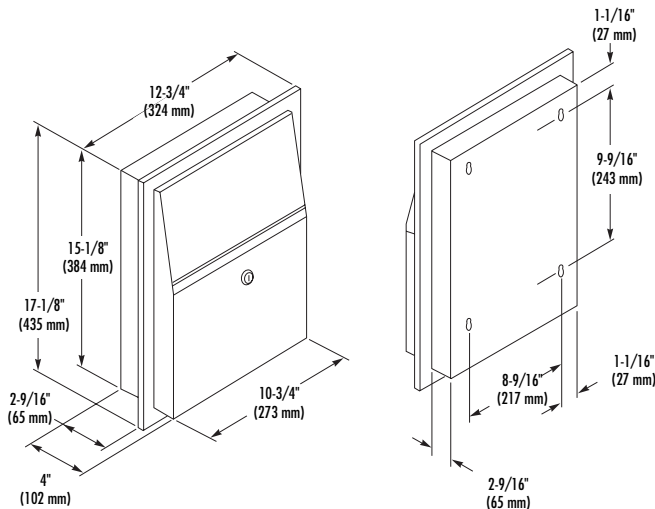

# NAPKIN DISPOSAL

- Semi-recessed
- Single End Compartment



## CONSTRUCTION:

- **FLANGE** fabricated of type 304 (18-8), 22 gauge stainless steel with exposed surfaces in architectural satin finish. One piece seamless construction, 1" wide with 1/4" return.
- **CABINET** fabricated of type 304 (18-8), 22 gauge stainless steel. All welded construction.
- **PUSH FLAP DOOR** fabricated of type 304 (18-8), 22 gauge stainless steel with exposed surfaces in architectural satin finish. Heavy duty stainless steel piano hinge. Self-closing flap door.
- **WASTE CONTAINER** fabricated of type 304 (18-8), 22 gauge stainless steel with tumbler locks keyed like other Bradley units.

## CAPACITY:

1.5 gal. (.2 cu. ft.)

## OPERATION:

Waste container removable from one side with finger grip. Furnished with waxed paper liner. Additional liners available from Bradley.

## INSTALLATION:

Requires partition opening 11"W x 15-3/8"H x 2-1/2"D. Top of wall opening 2'-9" above finished floor. Secure unit to framing with mounting screws (included) at holes provided. Shim at screw points as required.

## GUIDE SPECIFICATION:

Semi-recessed napkin disposal shall be fabricated of type 304 (18-8), 22 gauge stainless steel with exposed surfaces in satin finish. Self-closing push flap door and removable stainless steel receptacle with tumbler lock.

Overall dimensions: 12-3/4"W x 17-1/8"H x 4"D.

**Semi-recessed Napkin Disposal shall be Bradley Model 4722-10-15.**

**Document No. 8390**

This information is subject to change without formal notice.  
© 2007 Bradley Corporation  
3-13-2007

**Bradley**

P.O. Box 309, Menomonee Falls, WI 53052-0309  
Phone 1-800-BRADLEY FAX 262-253-4161  
Web Site: <http://www.bradleycorp.com>