

Recommended for mid to high traffic areas; not recommended for high vandal-prone areas.

2905-287300 Standard (110–120 volt, 13.6 amps, 60 Hz - White)

2905-2873CE—European Export (220–240 volt, 7 amps, 50 Hz - White)

Product Materials

COVER: 5/64" (1.9mm) thick steel one-piece cover with white epoxy coating. Cover fixed to the base with 4 Allen-head screws.

MOTOR: durable, maintenance-free shaded pole motor with safety thermostat and self-resetting thermal cut-off at 266°F (130°C). PP UL94-V0 with single inlet fan wheel.

HEATING ELEMENT: waved wire NiCr 40 heating element that incorporates a self-resetting thermal cut-off at 158°F (70°C).

ELECTRONIC CONTROL: two distances (15/25 cm) IR electronic detection sensor with zamak air outlet grill.

BASE PLATE: thermoplastic ABS UL 94-V0 base and single-inlet centrifugal scroll fan; with four Ø 5/16" (8mm) holes for wall mounting.

Guide Specification

Surface-mounted hand dryer shall be fabricated from one-piece 5/64" (1.9mm) thick steel. Cover shall have a white epoxy coating. The back base shall be fire-resistant plastic ABS UL 94-V0. The dryer shall be fitted with an infrared electronic sensor, zamak air outlet grill and shaded pole motor with safety thermostat and self-resetting thermal cut-off at 266°F (130°C). Dryer shall operate at 60 dB while delivering 194 CFM of air at 125.6°F (52°C) and 4,181 LFM during user-controlled drying cycle. The dryer shall have a total power of 1,640 W (2.2 Hp) with a consumption of 13.6 A (2905-2873) or 7 A (2905-2873CE).

Overall dimensions: 11-7/8"H x 10-1/16"W x 5-1/2"D (302mm x 256mm x 140mm).

Weight: 9.8 lb (4,45 kg).

Product Specifications

Voltage:	2905-2873 — 110–120 V 2905-2873CE — 220–240 V)	Consumption:	2905-2873 — 13.6 A 2905-2873CE — 7 A
Motor:	1/5 HP (140W)	RPM:	3,300
Nominal power:	1,640 W (2.2 Hp)	Heating element:	1,500 W (2 Hp)
Effective airflow:	166 CFM	Nominal airflow:	194 CFM
Noise level at 79":	60 dB	Airspeed:	4,181 LFM
Frequency:	50/60 Hz	Insulation:	Grounding required
Temperature (at 4" distance / 70°F):	125.6°F (52°C)	Certificates:	2905-2873 — UL 499/CSA C22.2 2905-2873CE — VDE GS/VDE EMC/CE GOST
Drying time:	38 seconds	Mounting:	Surface

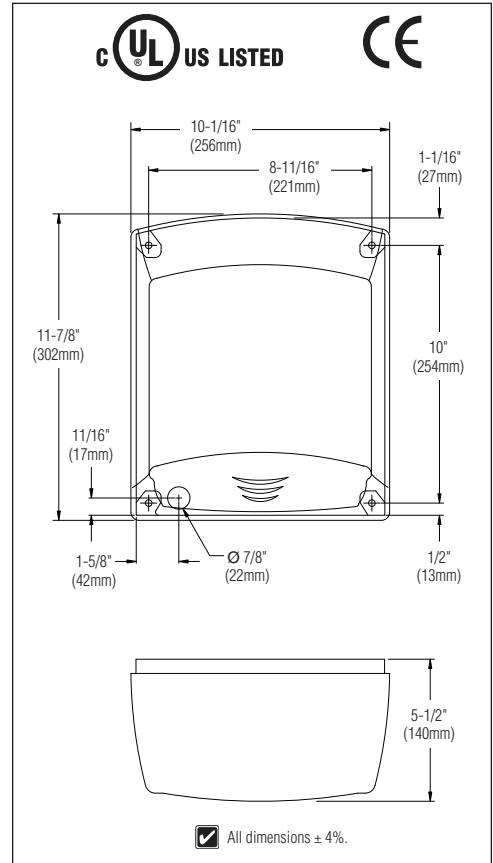

Operation

Place hands 3"–6" below air outlet grill to activate air flow. Dryer will stop two seconds after hands are removed from air flow.

Washroom Accessories
Document No. 8257