

- Standard Model 2877-280000 – 120 Volt, 17 amp, 60 Hz—Chrome-Plated**
- Model 2887-28 – 120 Volt, 17 amp, 60 Hz—Color (Specify Color)**

- Surface-Mounted
- Push Button Activation

Product Materials

COVER, NOZZLE AND PUSH BUTTON: rust and corrosion-free diecast aluminum with satined chrome over nickel finish.

MOTOR: PSC induction motor (brushless), 1/10 HP, thermally protected, self aligning quiet bearings, resilient ring motor mounts; no field lubrication required.

HEATING ELEMENT: 2000 watt nickel chromium heating element blower and inlet mounted (inaccessible through nozzle), protected by self resetting disc thermostat.

SWITCH TIMER: 25-amp rating, enclosed switch. 30-second timer Model impedance protected.

BLOWER: operates at 3450 RPM delivering 100 CFM at 130 deg. F. and average velocity of 5000 LFM.

BASE PLATE: diecast aluminum.

AIR INLET: integrally cast in cover.

COVER LOCKING: 1/4" diameter socket head safety screws; special wrench provided.

Operation

Press push button and release to activate dryer.

Installation

Verify all rough-in dimensions prior to installation. Secure base plate to wall with four 1/4" dia. fasteners suitable to the wall construction. Base knockouts allow either rear or front wiring. Connect electrical service to terminal board per cover mounted wiring diagram. Attach cover to base before energizing dryer at breaker panel.

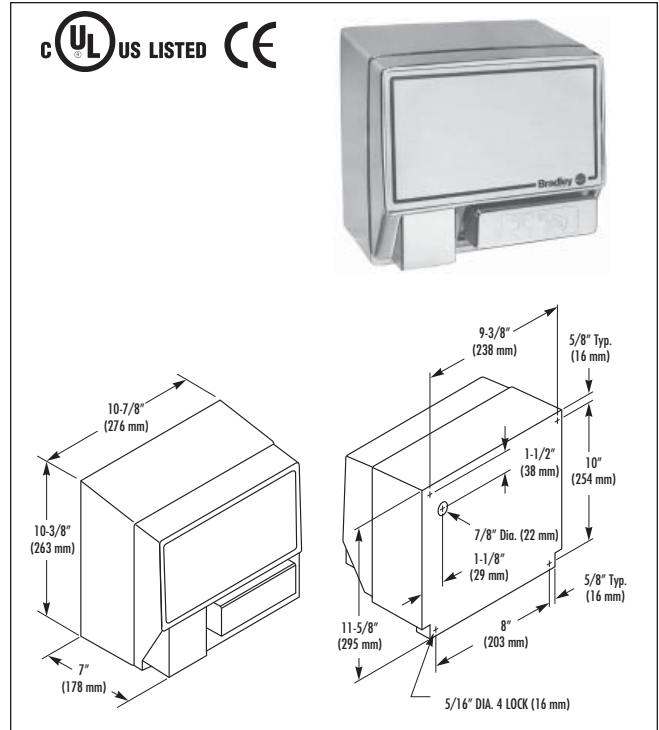

Optional Features

Feature	Suffix
<input type="checkbox"/> 208/240 Volt, 10 amp, 60 Hz	-53
<input type="checkbox"/> White epoxy finish	-33
<input type="checkbox"/> 220 Volt, 7.5 amp, 50 Hz	-48
<input type="checkbox"/> 230 Volt, 10 amp, 50 Hz	-49

- For Export (CE certified), specify (-49).

Guide Specification

Surface-mounted hand dryer cover shall be fabricated of rust and corrosion free diecast aluminum with integral nozzle. Motor of PSC induction type with self aligning, self lubricating, quiet bearings; thermally protected. Automatic reset thermostat protecting heating element. Dryer operates at 71 dB while delivering 120 CFM at 130 F and 5000 LFM average velocity for 30 sec.

Overall dimensions: 10-29/32"W x 11-5/8"H x 7"D (7-5/8" at nozzle tip).

**Washroom Accessories
Document No. 8255**

This information is subject to change without formal notice.

Always consult local and national codes for proper installation guidelines. Conformity and compliance to local and national codes is the responsibility of the installer.

9-30-2008

© 2008 Bradley Corporation
P.O. Box 309, Menomonee Falls, WI 53052-0309
Phone: 800.BRADLEY (800.272.3539) Fax: 262.253.4161
bradleycorp.com