

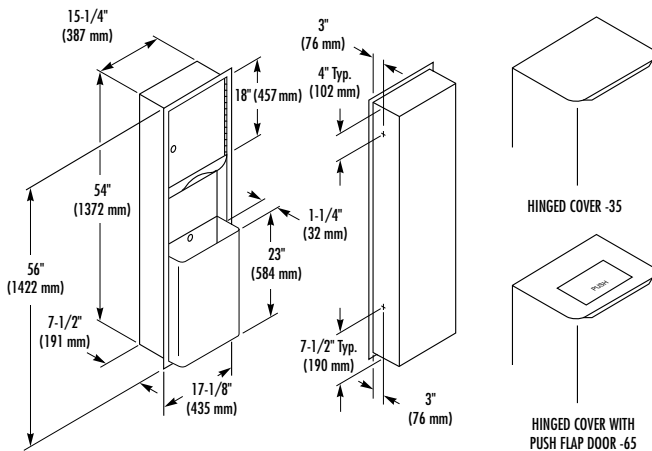

This unit meets "Barrier Free" requirements when mounted in accordance with local ordinances.

TOWEL DISPENSER/ WASTE RECEPTACLE

- Model 237 – Recessed
- Model 237-10 – Semi-recessed (recesses 3-1/2"; projects 4")
- Model 237-11 – Surface-Mounted (projects 7-1/2")



GUIDE SPECIFICATION:

Recessed combination towel dispenser and waste receptacle shall be fabricated of type 304 (18-8), 22 gauge stainless steel with exposed surfaces in satin finish. Cabinet doors with full length piano hinge and secured by tumbler lock. Towel dispenser capacity 1100 single-fold, 800 multi-fold or 600 C-fold towels. Removable 12 gal. stainless steel waste receptacle. Reusable vinyl liner is optional.

Overall dimensions: 17-1/8"W x 56"H x 8-3/4"D.

Recessed Combination Towel Dispenser and Waste Receptacle shall be Bradley Model 237.

Document No. 8145

This information is subject to change without formal notice.
© 2007 Bradley Corporation
9-20-2007

CONSTRUCTION:

- **FLANGE** fabricated of type 304 (18-8), 22 gauge stainless steel with exposed surfaces in architectural satin finish. One piece seamless construction, 1" wide with 1/4" return.
- **CABINET** fabricated of type 304 (18-8), 22 gauge stainless steel with exposed surfaces in architectural satin finish. Welded construction with seamless corners and burr-free edges.
- **DOOR** fabricated of type 304 (18-8), 18 gauge stainless steel. Warp resistant, with full length piano hinge and tumbler lock keyed like other Bradley units.
- **TOWEL DISPENSER** fabricated of type 304 (18-8), 22 gauge stainless steel. Rolled edge on dispenser opening.
- **WASTE RECEPTACLE** fabricated of type 304 (18-8), 22 gauge stainless steel. All welded construction. Secured to cabinet with tumbler lock keyed like other Bradley units.
- **LINER** (optional) heavy duty stitched vinyl coated nylon. Part # P11-004.
- **CUP DISPENSER** (optional) fabricated of type 304 (18-8), 22 gauge stainless steel.
- **HINGED COVER** (optional) fabricated of type 304 (18-8), 22 gauge stainless steel with exposed surfaces in architectural satin finish. Heavy duty stainless steel piano hinge.
- **PUSH FLAP DOOR** (optional) fabricated of type 304 (18-8), 22 gauge stainless steel with exposed surfaces in architectural satin finish. Heavy duty stainless steel piano hinge. Self-closing flap door is embossed "PUSH".

CAPACITY:

Towel Dispenser - 1100 single-fold, 800 multi-fold or 600 C-fold paper towels; Waste Container - 12 gal. (1.6 cu. ft.); Cup Dispenser (optional) - 100 3-oz. cups.

OPERATION:

Towel dispenser holds single-fold, multi-fold or C-fold towels with use of special adaptor. Receptacle removable for servicing by unlocking waste container.

INSTALLATION:

Recessed unit requires rough wall opening 15-3/4"W x 54-1/2"H x 7-1/2"D (Semi-recessed unit only 3-1/2" deep). Top of wall opening 5'-2" min. to 6'-6" max. above finished floor. Secure to framing with mounting screws (included) at holes provided. Shim at screw points as required.

OPTIONAL FEATURES

Feature	Suffix
<input type="checkbox"/> Hinged Cover	-35
<input type="checkbox"/> Large Capacity Waste Receptacle - 18 gal. (Not ADA Compliant)	-36
<input type="checkbox"/> Hinged Cover with Push Flap Door	-65



P.O. Box 309, Menomonee Falls, WI 53052-0309
Phone 1-800-BRADLEY FAX 262-253-4161
Web Site: <http://www.bradleycorp.com>